

Cable Multi 4 core , AWG-18 UL1015 PVC Black  
Lead wire length 1500 ± 25 mm.  
Blue/Black/Brown/Green-Yellow  
With terminal Female with insulation #250

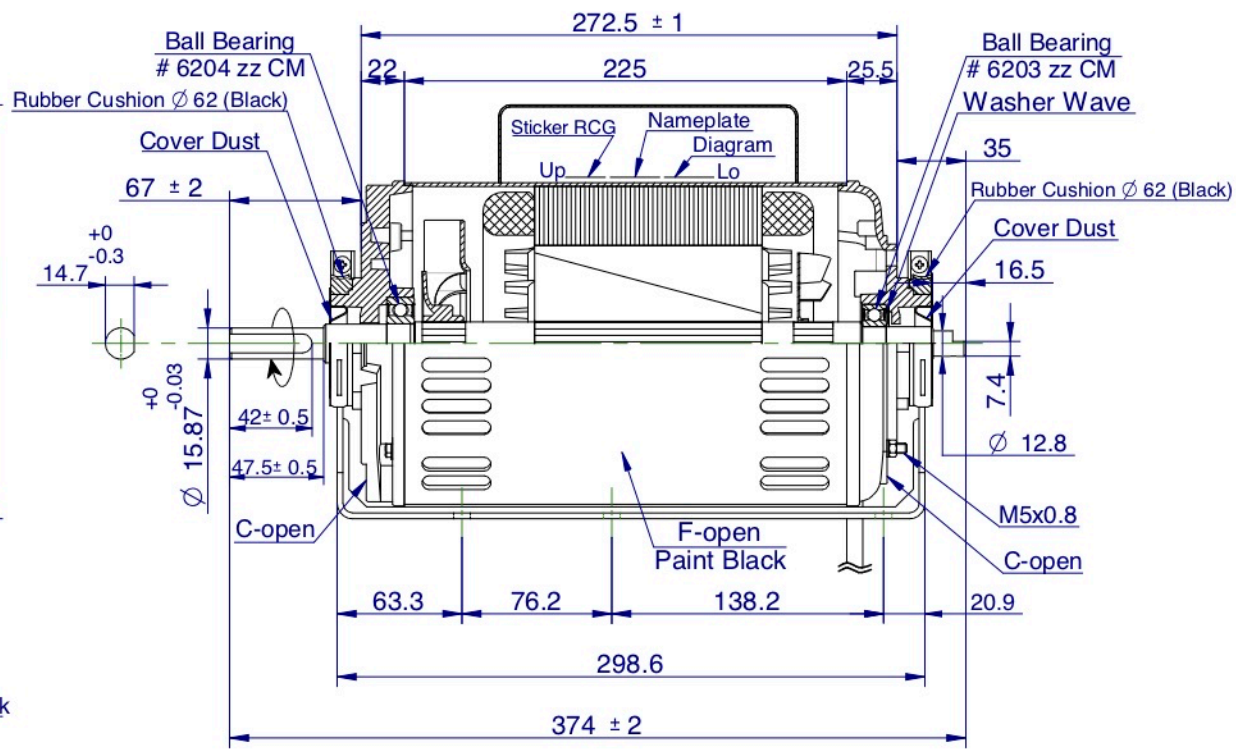

RCT90-7504S-ODP-A02			
750W , 4P , 4.2Amp	Cap. 20 mfd	Frame 56	
240V , 1Ph , 50Hz	Rating Cont	Mounting Cradle	
Rpm 1400	Ins. Class B	Serial No. DDMYYxxxx	

**WARNING**  
MOTOR FITTED WITH INTERNAL AUTO-RESET OVERLOAD AND MAY RESTART WITHOUT WARNING

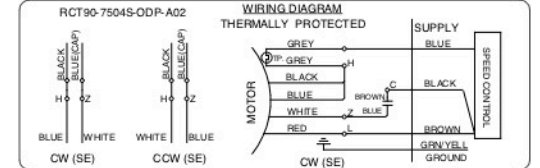

DATA TEST NO.	W443-2245-SL	
APPLICABLE MODEL	PM3100196	
SPECIFICATION	NO. OF PHASE	1 PHASE
	NO. OF POLE	4 P.
	RATED RPM.	50Hz 1400 60Hz ---
	VOLTAGE	240 V.
	CURRENT	5.21 A.
WINDING RESISTANCE (REF. 20")	OUTPUT	876 W.
	M COIL	3.06 Ω
	S COIL	8.59 Ω
	SP1 COIL	--- Ω
THERMAL PROTECTOR	SP2 COIL	--- Ω
		17AM - 150°C Refer P/N.R330-0035
INSULATION CLASS	B	
METHOD OF COOLING	DPFC	
DEGREE OF PROTECTION	IP20	
WEIGHT	21.65 KGS.	

**STICKER RCG**

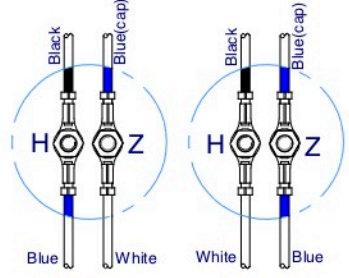

**BOARD TERMINAL**

- Notes :
1. After the motor is complete, applied rust proof oil (Caltex oil) at shaft end.
  2. The tensile strength of each lead wire at least 4 Kgs.
  3. The runout of the shaft end circumference 0.08 mm.

**NAMEPLATE**

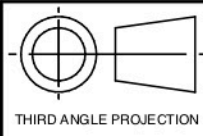

NON SCALES

**DIAGRAM**

THIS DRAWING MAY BE USED IN WHOLE OR PART ,PROVIDED THE PIONEER MOTOR NAME & LOGO ARE VISIBLE IN ANY REPRODUCTION.

FINISH:	DESCRIPTION:	REFER TO :
ASSEMBLY	MOTOR OUTLINE	QR2874 ECN No.8915
ROYCECROSS	Q'TY 1	APPLICATION INDOOR MOTOR
		Group Code: FF90/100B