

2-Lead AWG-20 UL1015 @ 1300 ± 25 mm. (Orange/Orange)  
 With terminal #250 & Insulation sleeve  
 4-Lead AWG-20 UL1015 @ 1300 ± 25 mm. (Blue/Brown/Grey/White)  
 With terminal splice : H29101 (6 mm.)  
 Ground wire AWG-18 UL1015 @ 1300 ± 25 mm.  
 With ring terminal Ø5 (Green/Yellow)

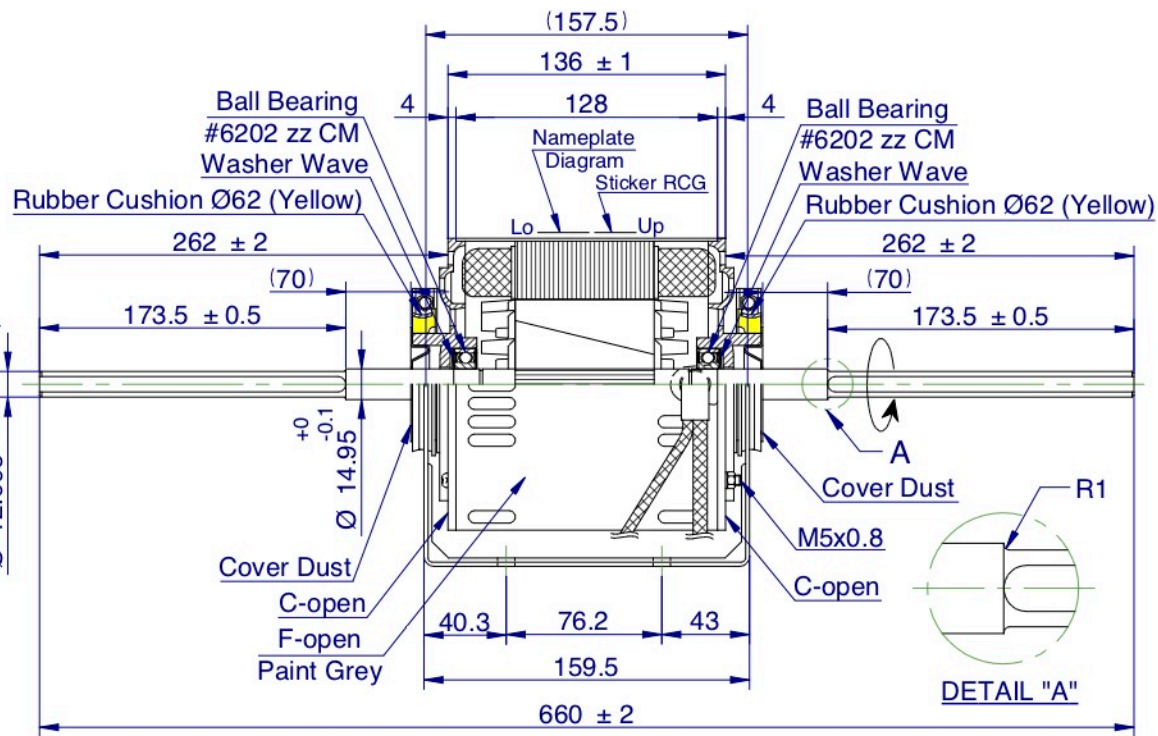

<b>RCT85-7504DS-ODP-C02R</b>					
0.75kW , 4P , 4.9Amp	Cap.	20 mfd	Frame	48	
240V , 1Ph , 50Hz	Rating	Cont	Mounting	Res.mt	
Rpm 1360/1310/1260	Ins. Class	B	Serial No.	DDMMYYXXXX	

**WARNING**

MOTOR FITTED WITH INTERNAL AUTO RESET OVERLOAD AND MAY RESTART WITHOUT WARNING

WIRING DIAGRAM THERMALLY PROTECTED

DATA TEST NO.	W443-1291-SL	
APPLICABLE MODEL	PM4100234	
SPECIFICATION	NO. OF PHASE	1 PHASE
	NO. OF POLE	4 P.
	RATED RPM.	50Hz 1360/1310/1260 60Hz ---
	VOLTAGE	240 V.
	CURRENT	4.90 A.
WINDING RESISTANCE	OUTPUT	750 W.
	M COIL	5.56 Ω
	S COIL	15.23 Ω
	SP1 COIL	1.07 Ω
(REF. 20")	SP2 COIL	1.07 Ω
THERMAL PROTECTOR	17AM - 150°C Refer P/N.R330-0035	
INSULATION CLASS	B	
METHOD OF COOLING	A.O.M.	
DEGREE OF PROTECTION	IP20	
WEIGHT	10.00 KGS.	

**STICKER RCG**

**NAMEPLATE**

**DIAGRAM**

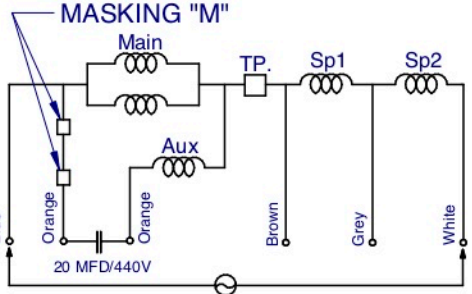

Remark : Part No. Capacitor R330-5426

Notes :

1. After the motor is complete, applied rust proof oil at shaft end.
2. The tensile strength of each lead wire at least 4 Kgs.
3. The runout of the shaft end circumference 0.22 mm.

THIS DRAWING MAY BE USED IN WHOLE OR PART ,PROVIDED THE PIONEER MOTOR NAME & LOGO ARE VISIBLE IN ANY REPRODUCTION.

THIRD ANGLE PROJECTION	FINISH:	DESCRIPTION:	REFER TO :
	ASSEMBLY	MOTOR OUTLINE	PM4100170 ECN No.9118
	ROYCECROSS	Q'TY	APPLICATION
	NON SCALES	1	INDOOR MOTOR
		Group Code:	FF85B