

DATA TEST NO.	W443-1118-SL	
APPLICABLE MODEL	PM3102232 A1	
SPECIFICATION	NO. OF PHASE	1 PHASE
	NO. OF POLE	6 P.
	RATED RPM.	50Hz 900 60Hz ---
	VOLTAGE	240 V.
	CURRENT	3.00 A.
WINDING RESISTANCE (REF. 20")	OUTPUT	450 W.
	M COIL	11.05 Ω
	S COIL	11.93 Ω
	SP1 COIL	6.79 Ω
THERMAL PROTECTOR	17AM - 150°C Refer P/N.R330-0035	
INSULATION CLASS	B	
METHOD OF COOLING	A.O.M.	
DEGREE OF PROTECTION	IP20	
WEIGHT	9.50 KGS.	

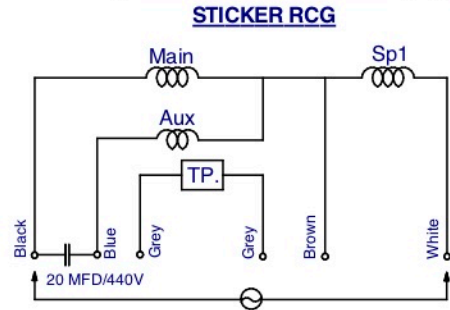

Remark : Part No. Capacitor R330-5426

- Notes :
1. After the motor is complete, applied rust proof oil (Caltex oil) at shaft end.
 2. The tensile strength of each lead wire at least 4 Kgs.
 3. The runout of the shaft end circumference 0.08 mm.

RCT85-4506S-TE-D02S			
0.45kW , 6P , 3.0Amp	Cap. 20 mfd	Frame 48	
240V , 1Ph , 50Hz	Rating Cont	Mounting Lug	
Rpm 900	Ins. Class B	Serial No. DDMMYYXXXX	

WARNING

MOTOR FITTED WITH INTERNAL AUTO RESET OVERLOAD AND MAY RESTART WITHOUT WARNING

THIS DRAWING MAY BE USED IN WHOLE OR PART ,PROVIDED THE PIONEER MOTOR NAME & LOGO ARE VISIBLE IN ANY REPRODUCTION.

THIRD ANGLE PROJECTION	FINISH:	DESCRIPTION:	REFER TO :
	ASSEMBLY	MOTOR OUTLINE	ECN No.8354
	ROYCECROSS	Q'TY 1	APPLICATION OUTDOOR MOTOR
NON SCALES			