

<b>RCT85-3006S-TE-M02</b>			
0.30kW , 6P , 2.7Amp	Cap. 6 mfd	Frame 48	
240V , 1Ph , 50Hz	Rating Cont	Mounting Nil	
Rpm 910/860/810	Ins. Class B	Serial No. DDMMYYXXXX	

**WARNING**

MOTOR FITTED WITH INTERNAL AUTO RESET OVERLOAD AND MAY RESTART WITHOUT WARNING

WIRING DIAGRAM THERMALLY PROTECTED

DATA TEST NO.	W443-1508-SL	
APPLICABLE MODEL	PM310375 A1	
SPECIFICATION	NO. OF PHASE	1 PHASE
	NO. OF POLE	6 P.
	RATED RPM.	50Hz 910/860/810 60Hz ---
	VOLTAGE	240 V.
	CURRENT	2.70 A.
WINDING RESISTANCE (REF. 20°)	OUTPUT	300 W.
	M COIL	9.26 Ω
	S COIL	46.09 Ω
	SP1 COIL	4.08 Ω
	SP2 COIL	2.08 Ω
THERMAL PROTECTOR	17AM - 150°C Refer P/N.R330-0035	
INSULATION CLASS	B	
METHOD OF COOLING	A.O.M.	
DEGREE OF PROTECTION	IP54	
WEIGHT	8.20 KGS.	

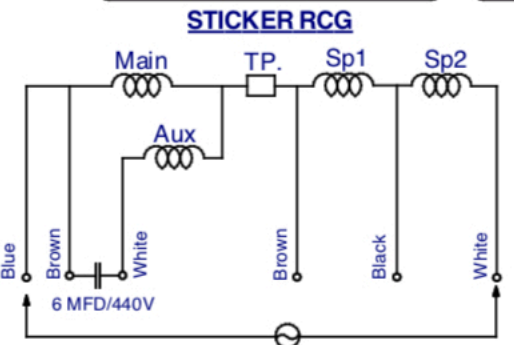

Remark : Part No. Capacitor R330-4095

Notes :

- After the motor is complete, applied rust proof oil at shaft end.
- The tensile strength of each lead wire at least 4 Kgs.
- The runout of the shaft end circumference 0.08 mm.

THIS DRAWING MAY BE USED IN WHOLE OR PART ,PROVIDED THE PIONEER MOTOR NAME & LOGO ARE VISIBLE IN ANY REPRODUCTION.

THIRD ANGLE PROJECTION

NON SCALES

FINISH:	DESCRIPTION:	REFER TO :
ASSEMBLY	MOTOR OUTLINE	ECN No. 7321,8354
CUSTOMER:	Q'TY	APPLICATION
ROYCECROSS	1	OUTDOOR MOTOR
		Group Code: FF85B

**ROYCECROSSGROUP**