

REV.	DESCRIPTION	DATE	CHKD	APPD	ITEMS LIST			
					ITEM No.	QTY.	DESCRIPTION	MATERIAL
					1	1	INTERMEDIATE ROD PLATE	UNS C84400 HIGH STRENGTH COPPER ALLOY
					2	1	KEEPER PLATE	UNS C84400 HIGH STRENGTH COPPER ALLOY
					3	-	-	-
					4	1	M10 U-BOLT	316 STAINLESS STEEL
					5	2	M10 NUT	316 STAINLESS STEEL
					6	2	M10 FLAT WASHER	316 STAINLESS STEEL
					7	2	M10 SPRING WASHER	316 STAINLESS STEEL

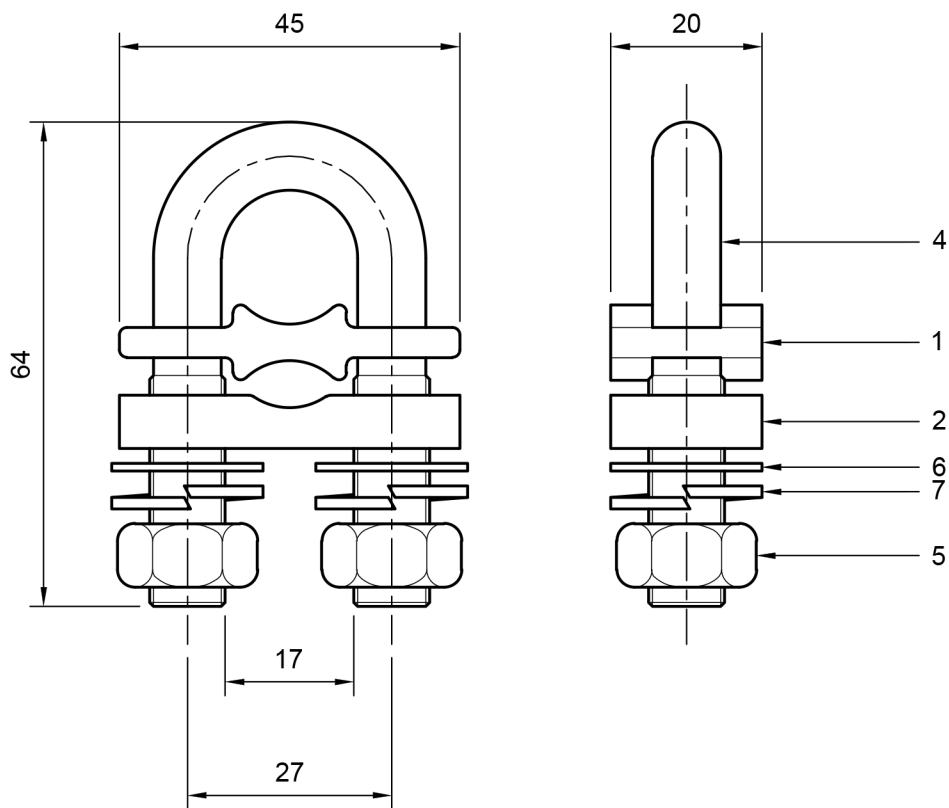

LPI[®]
 LIGHTNING PROTECTION INTERNATIONAL
 40 BATHURST DRIVE, HUNTINGFIELD, TASMANIA 7055

ROYCECROSSGROUP

CLIENT		VARIOUS	
LIGHTNING PROTECTION INTERNATIONAL U-BOLT CLAMP UBRC35120 ASSEMBLY			SCALE 1:1
DRG. No. LPI – UBRC35120			A4
SHT. 001		REVISION 0	
DRAWN MC	CHECKED G. TURVEY	APPROVED M. AUSTIN	
DESIGNED GT	DATE 03-03-2014	DATE 03-03-2014	

LPI-UBC-002

Rev. 0